

1 (1x)

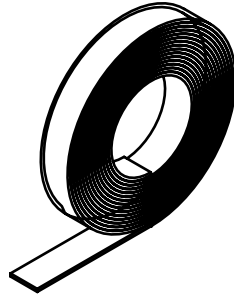

2 (1x)

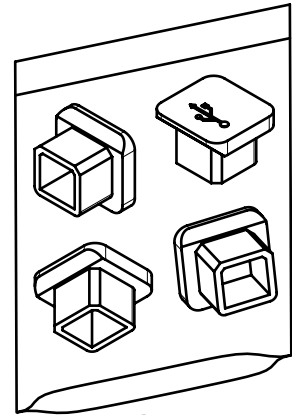

3 (1x)

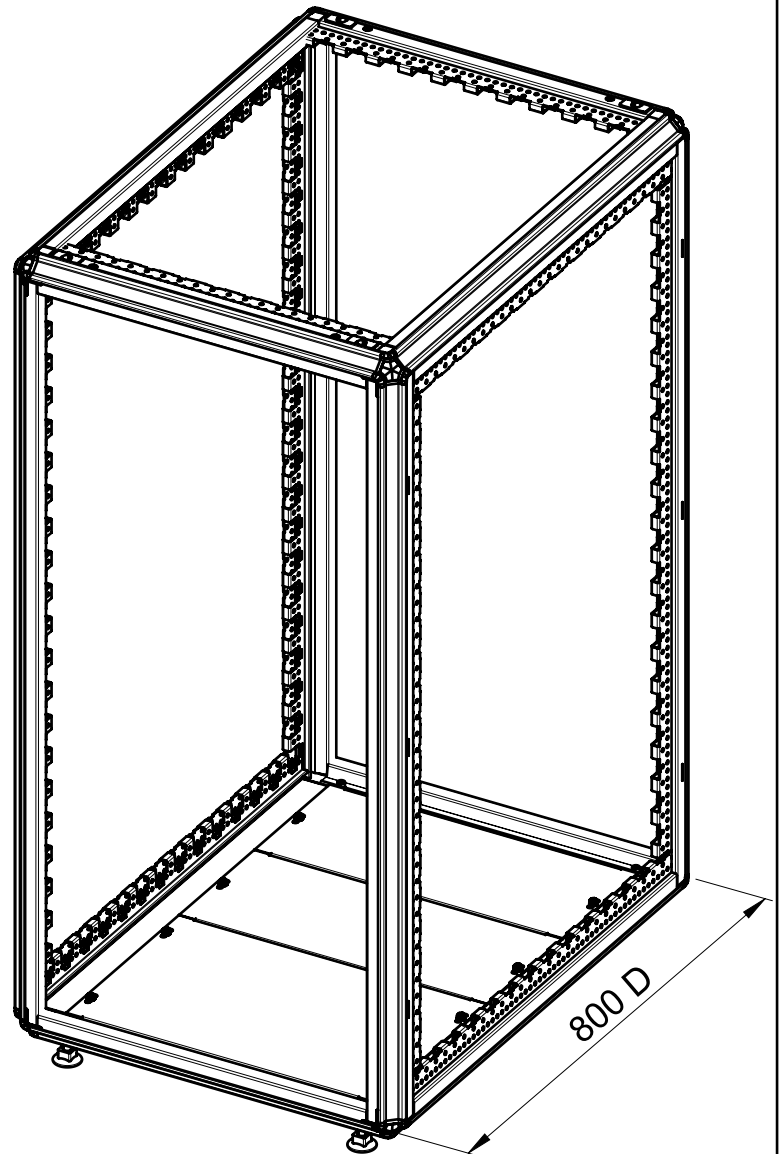
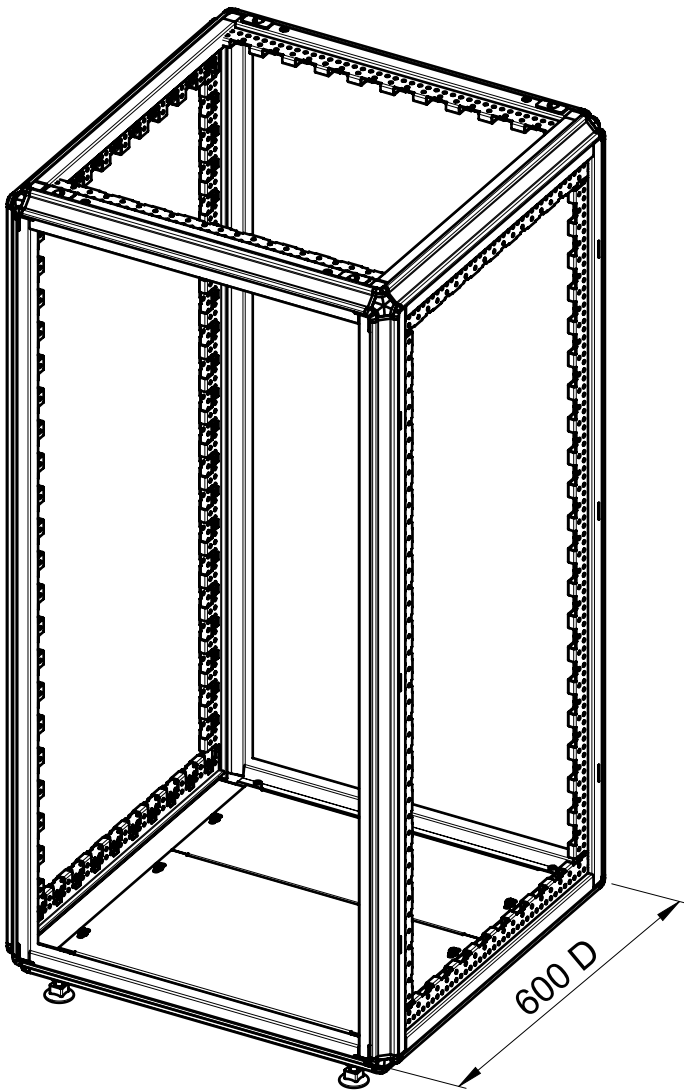

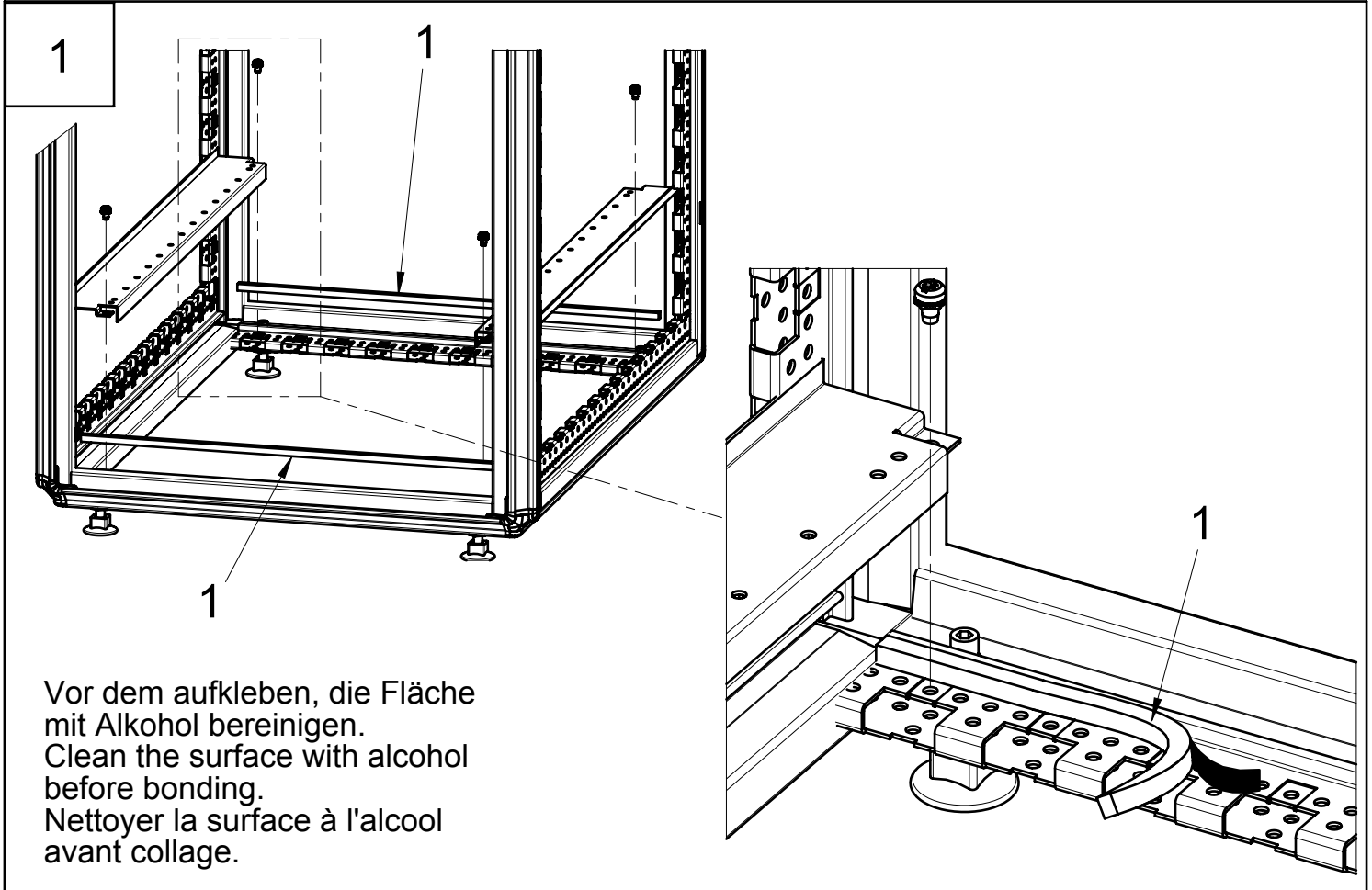

Vor dem aufkleben, die Fläche mit Alkohol bereinigen.  
Clean the surface with alcohol before bonding.  
Nettoyer la surface à l'alcool avant collage.

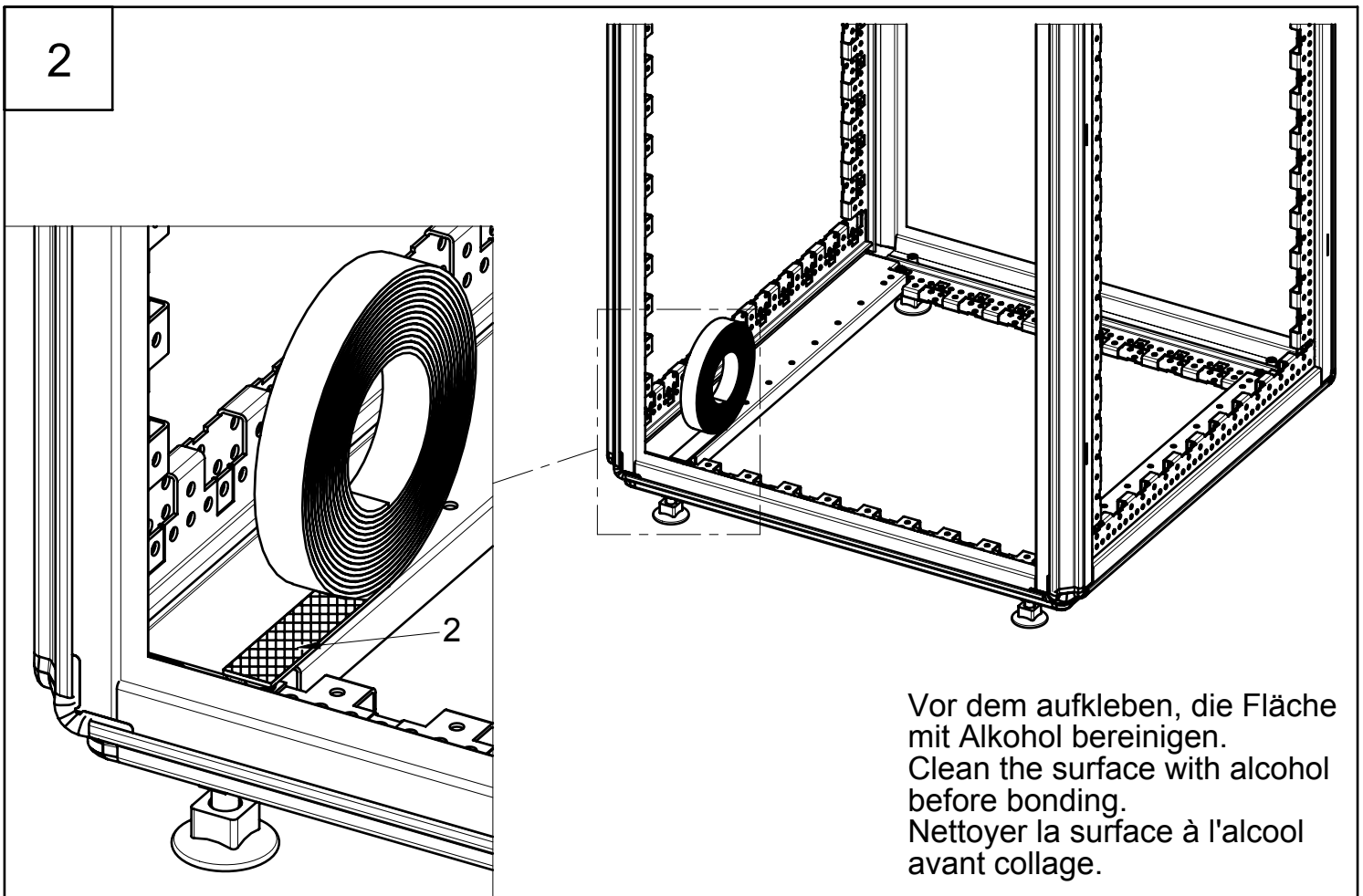

Vor dem aufkleben, die Fläche mit Alkohol bereinigen.  
Clean the surface with alcohol before bonding.  
Nettoyer la surface à l'alcool avant collage.

Grosser Abbug  
Big bend  
Grand pli

Kleiner Abbug  
Small bend  
Petit pli

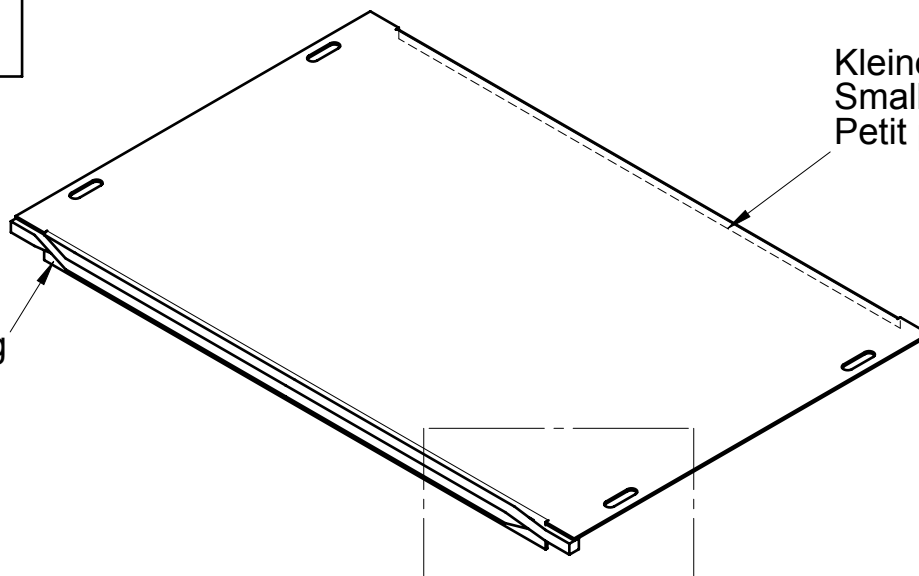

Step 1

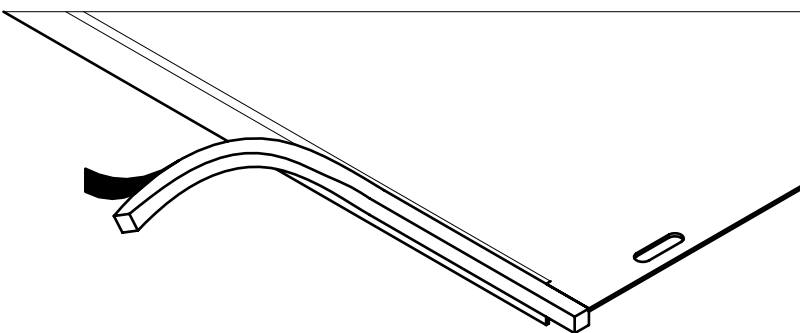

Step 2

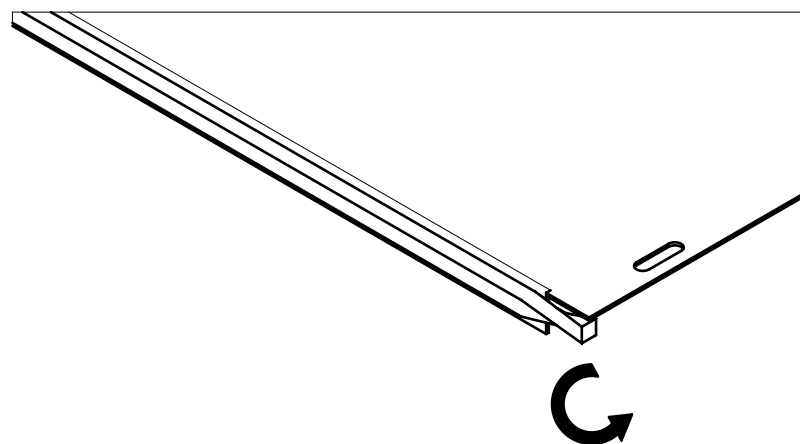

Step 3

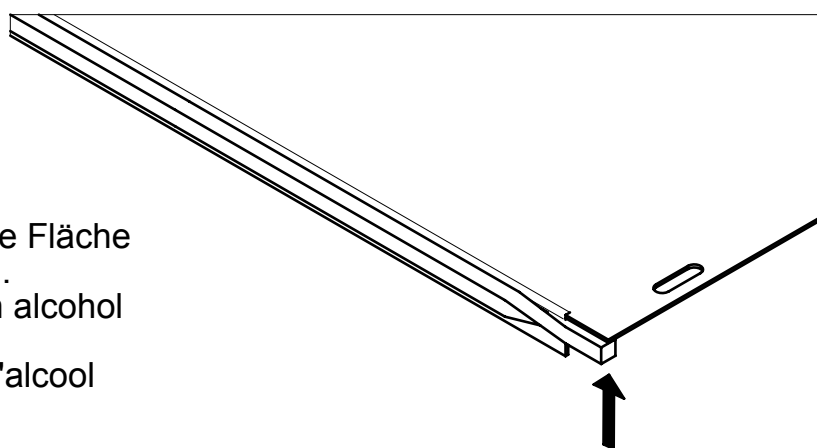

Vor dem aufkleben, die Fläche  
mit Alkohol bereinigen.  
Clean the surface with alcohol  
before bonding.  
Nettoyer la surface à l'alcool  
avant collage.

Step 1

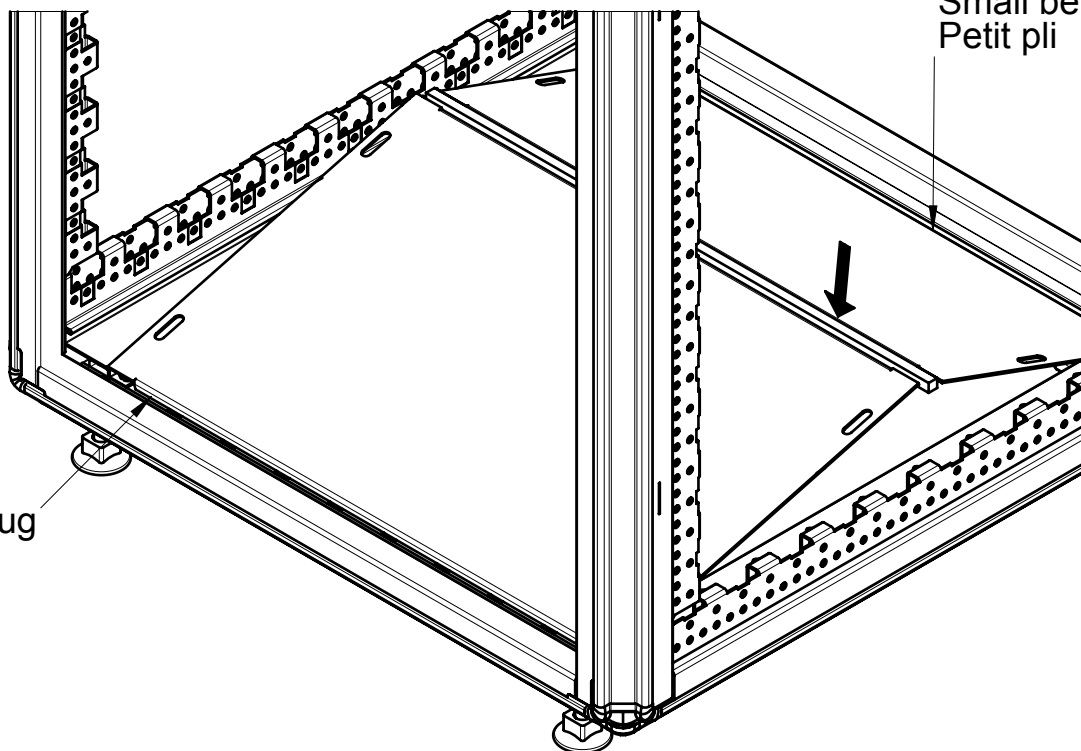

Kleiner Abbug  
Small bend  
Petit pli

Kleiner Abbug  
Small bend  
Petit pli

Step 2

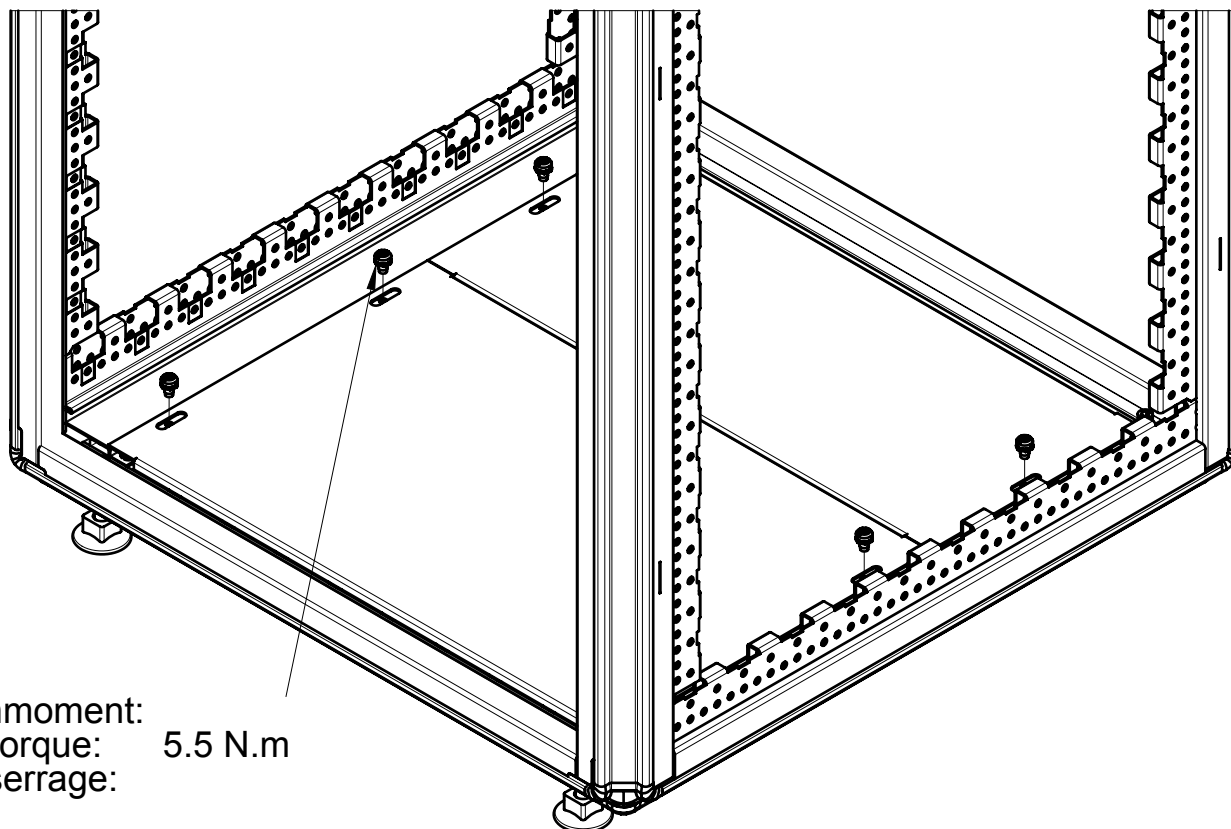

Anzugsdrehmoment:  
Tightening torque: 5.5 N.m  
Couple de serrage:

3

800D

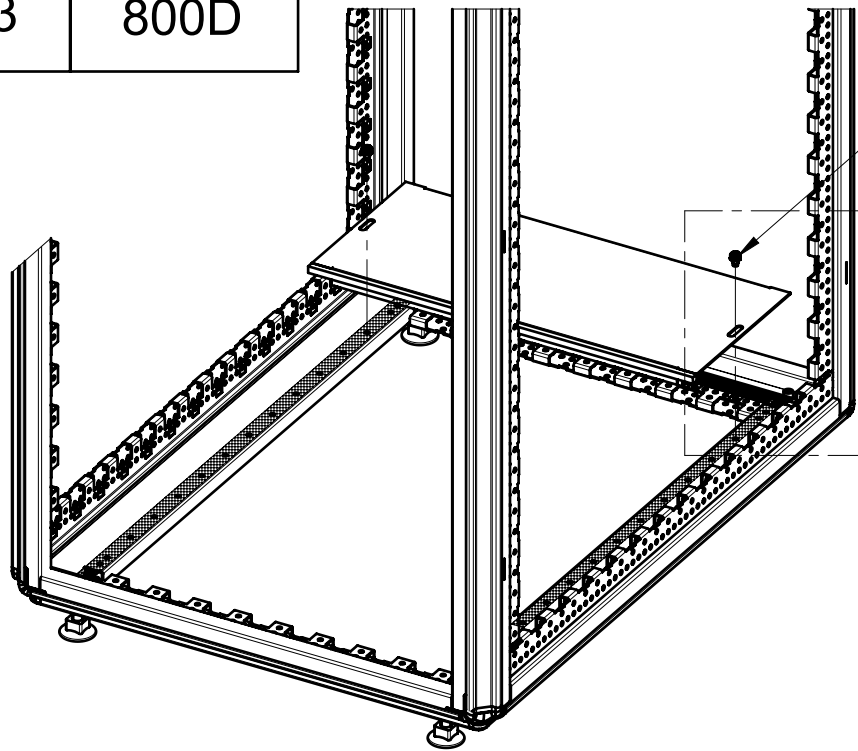

Anzugsdrehmoment:  
Tightening torque: 5.5 N.m  
Couple de serrage:

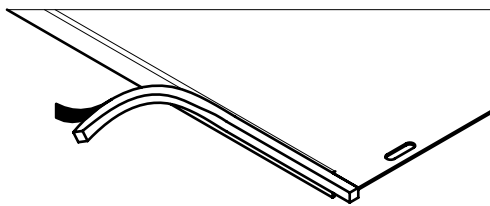

Step 1

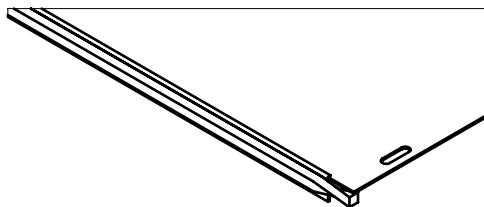

Step 2

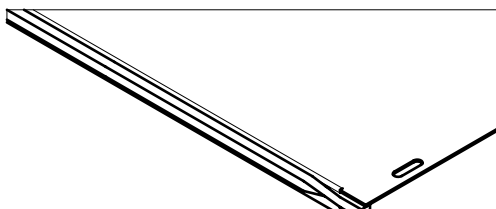

Step 3

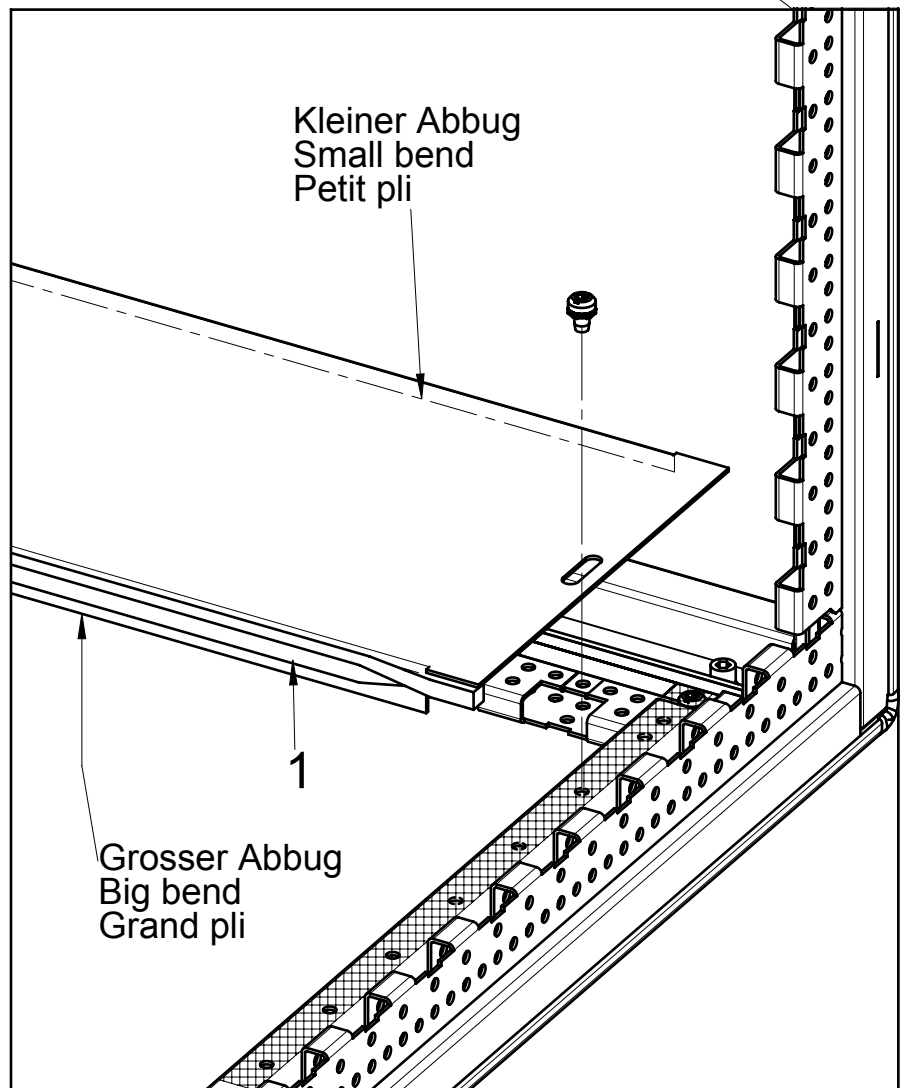

Kleiner Abbug  
Small bend  
Petit pli

Grosser Abbug  
Big bend  
Grand pli

Vor dem aufkleben, die Fläche mit Alkohol bereinigen.  
Clean the surface with alcohol before bonding.  
Nettoyer la surface à l'alcool avant collage.

Grosser Abbug  
Big bend  
Grand pli

Kleiner Abbug  
Small bend  
Petit pli

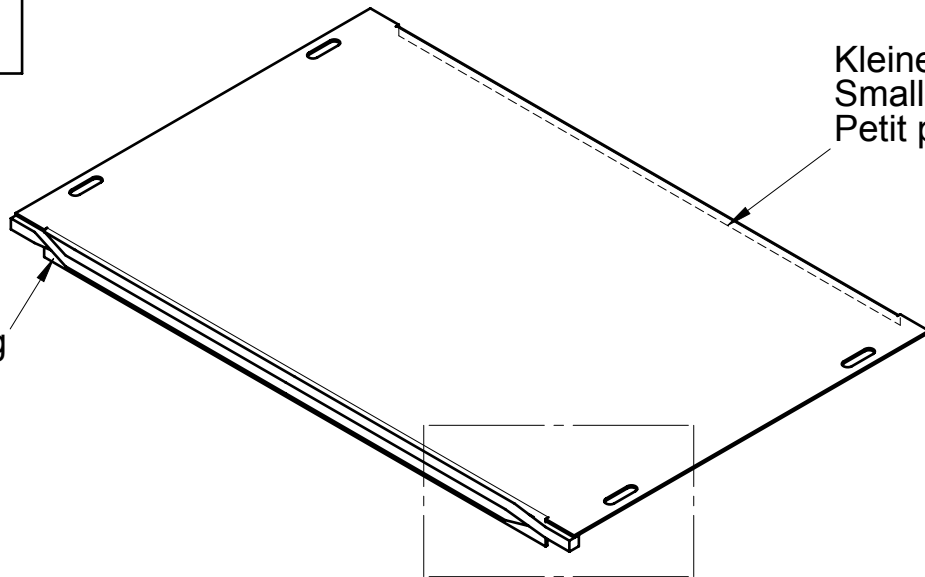

Step 1

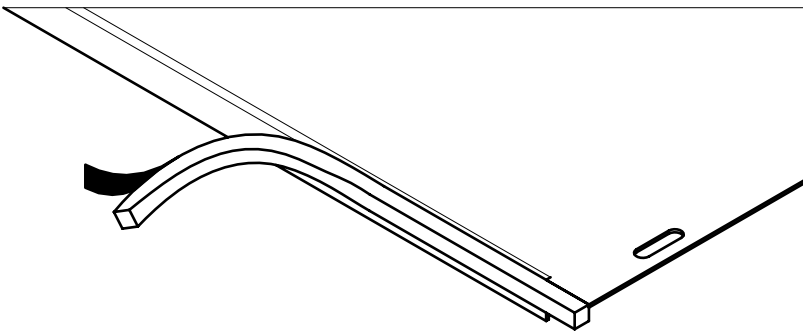

Step 2

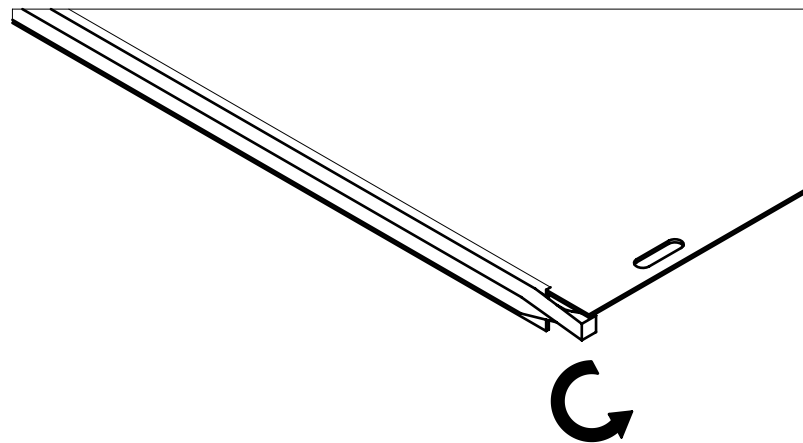

Step 3

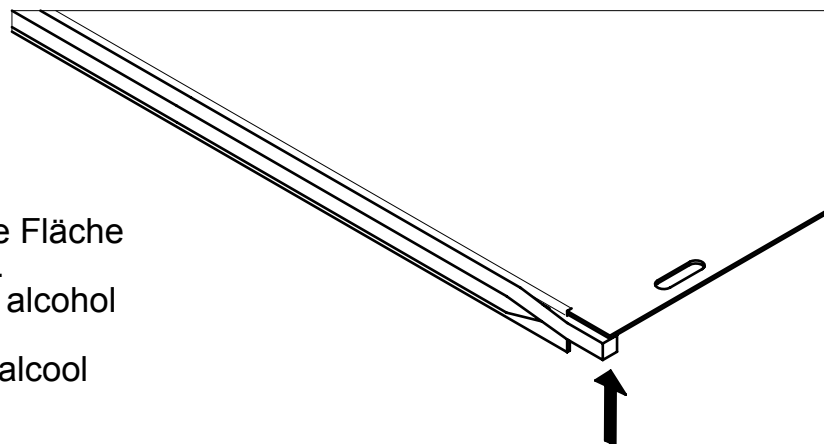

Vor dem aufkleben, die Fläche  
mit Alkohol bereinigen.  
Clean the surface with alcohol  
before bonding.  
Nettoyer la surface à l'alcool  
avant collage.

Step 1

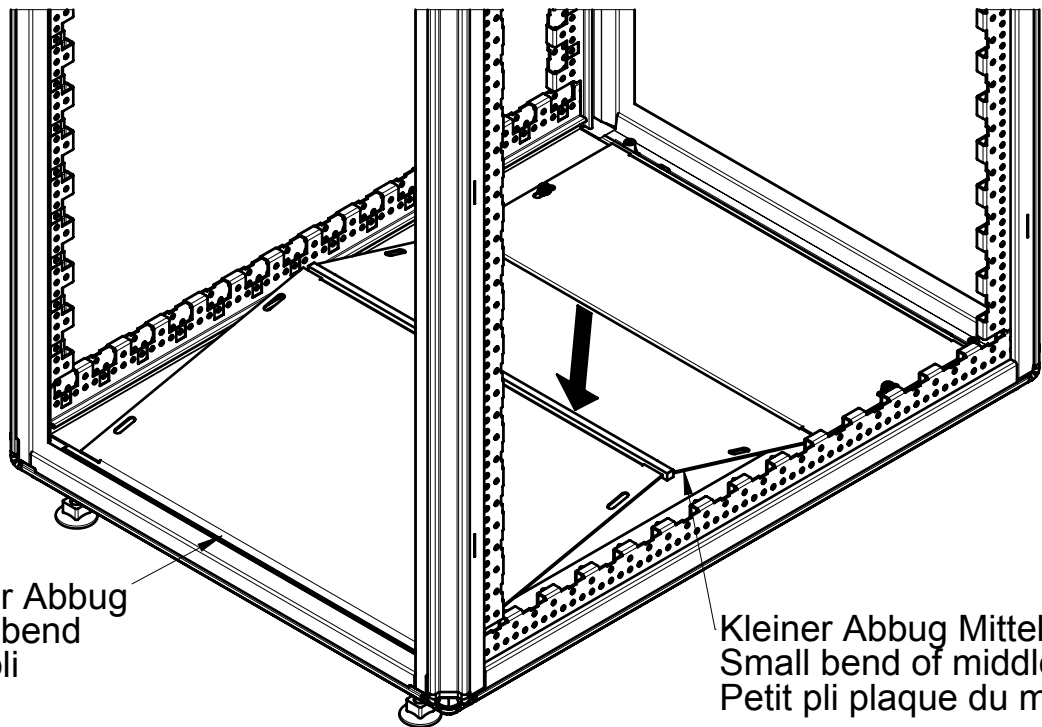

Kleiner Abbug  
Small bend  
Petit pli

Kleiner Abbug Mittelplatte  
Small bend of middle plate  
Petit pli plaque du milieu

Step 2

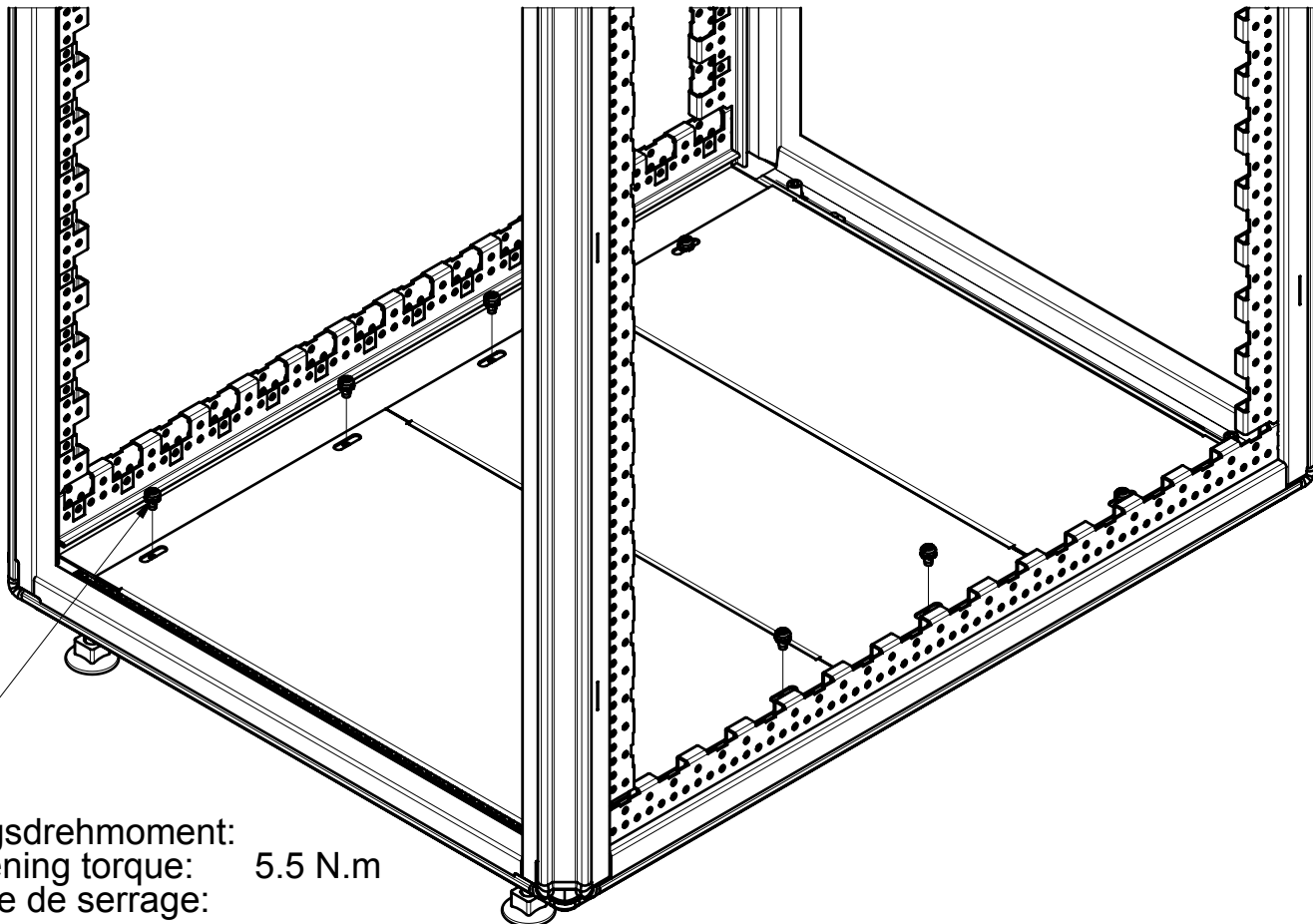

Anzugsdrehmoment:  
Tightening torque: 5.5 N.m  
Couple de serrage: